

# Vector Frame Counter 02

## VFC-02

Vector Frame™ counters compliment the Vector Frame series of exhibit kits, but are also ideal for any stand-alone event or display. Vector Frame counters couple simple extrusion-based frames with push-fit graphics or rigid sintra graphics. Tables are available in four colored finishes. Custom sizes also available.



## features and benefits:

- Feature push-fit fabric graphics and simple extrusion based frames
- Choose from four tabletop finishes
- Easy step-by-step instructions
- Wheeled portable shipping case
- Lifetime limited warranty against manufacturer defects

## dimensions:

### Hardware

Assembled unit:  
55.13" w x 40.5" h x 22.5" d  
1400mm(w) x 1029mm(h) x 572mm(d)

Approximate weight:  
64 lbs / 30 kg

### Graphic

Refer to related graphic template for more information.

Visit:  
<https://www.theexhibitorshandbook.com/download-graphic-templates>

### Shipping

Packing case(s)  
1 OCH2

Shipping dimensions:  
52" l x 29" h x 15" d  
1321mm(l) x 737mm(h) x 381mm(d)

Approximate shipping weight:  
94 lbs / 43 kg

## additional information:

Graphic material:  
Dye-sublimated SEG push-fit fabric

Counter holds max weight  
100 lbs / 46 kg

When included in a larger kit, a different packaging solution will be listed to accommodate all contents of the kit. Individual packaging no longer provided.

### Tabletop Colors:

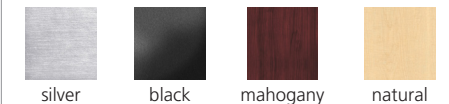

silver

black

mahogany

natural



This product may include the following materials for recycle:

aluminum, select wood, fabric, cardboard, paper, steel, and plastics.

We are continually improving and modifying our product range and reserve the right to vary the specifications without prior notice. All dimensions and weights quoted are approximate and we accept no responsibility for variance. E&OE. See Graphic Templates for graphic bleed specifications.

# Included In Your Kit

Tools, Components, & Connectors



5MM ALLEN-T x1

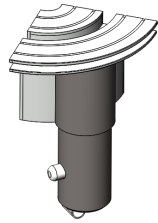

CB10-R x8



TUBE-30-910 x4

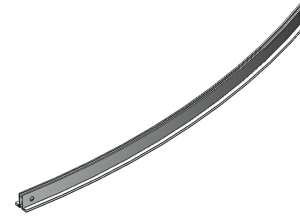

PHFC2-8R-30-L-L-IN x2

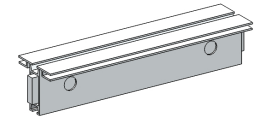

PHFC2-200-L-L x4

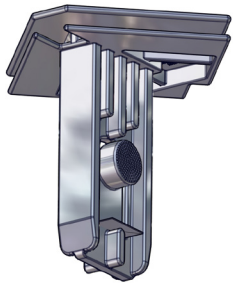

PMFC2-90-CAP x4

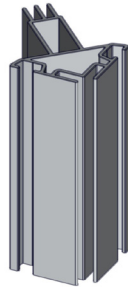

PMFC2-90-986-L1-L1 x2

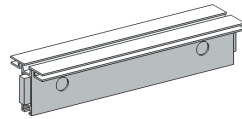

PHFC2-300-L-L x4

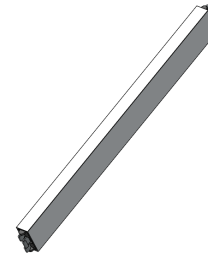

PH1-288-L-L x4



PE-1000 x2



VFC-02-INT-SHLF x1

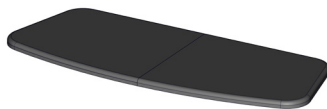

VFC-02-CT x1

Graphics

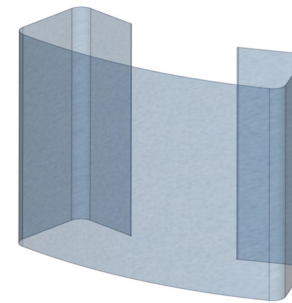

VFC-02-A-G x1



VFC-02-B-G x1

# Exploded View

VFC-02  
Section 1

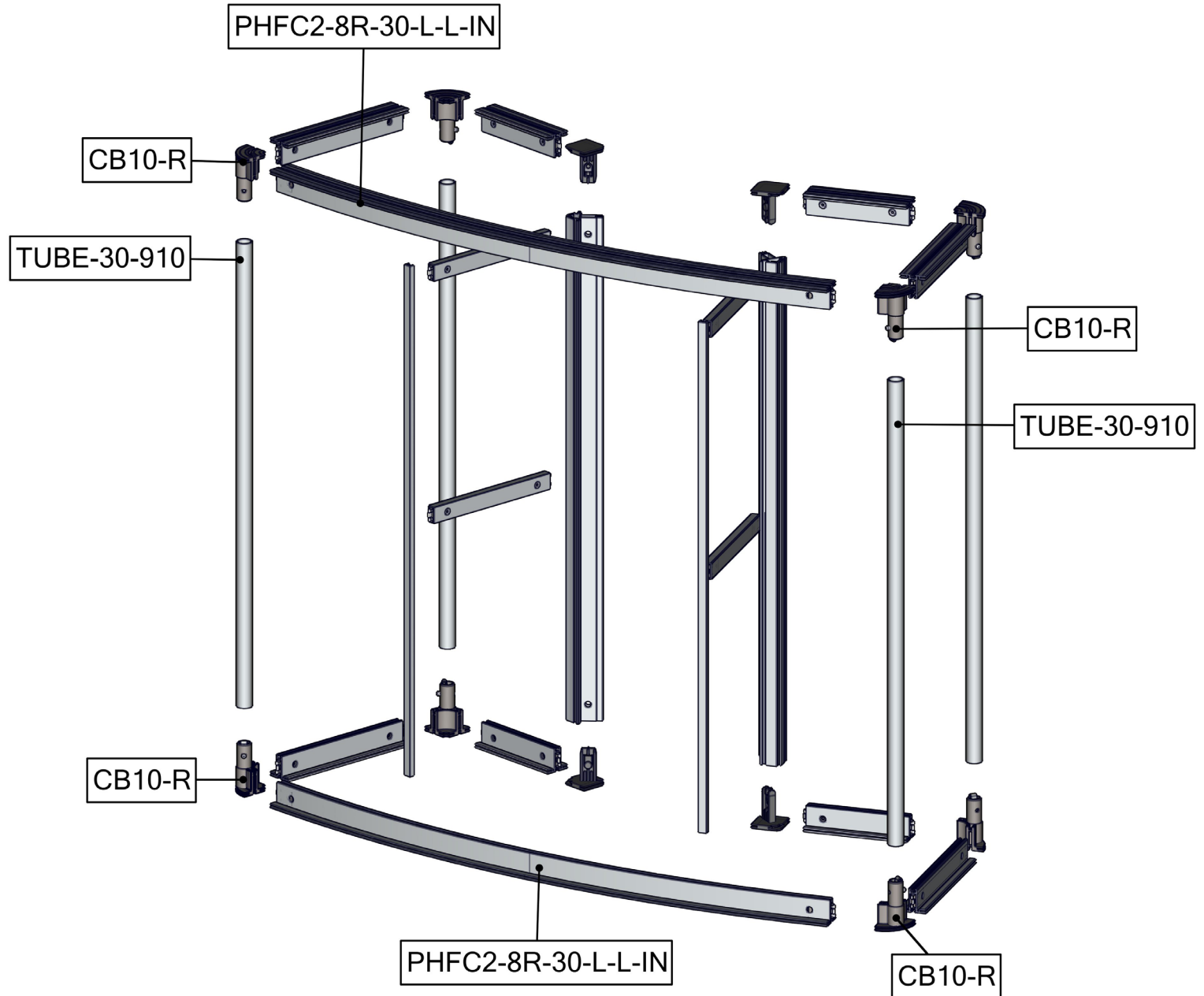

# Exploded View

VFC-02  
Section 2

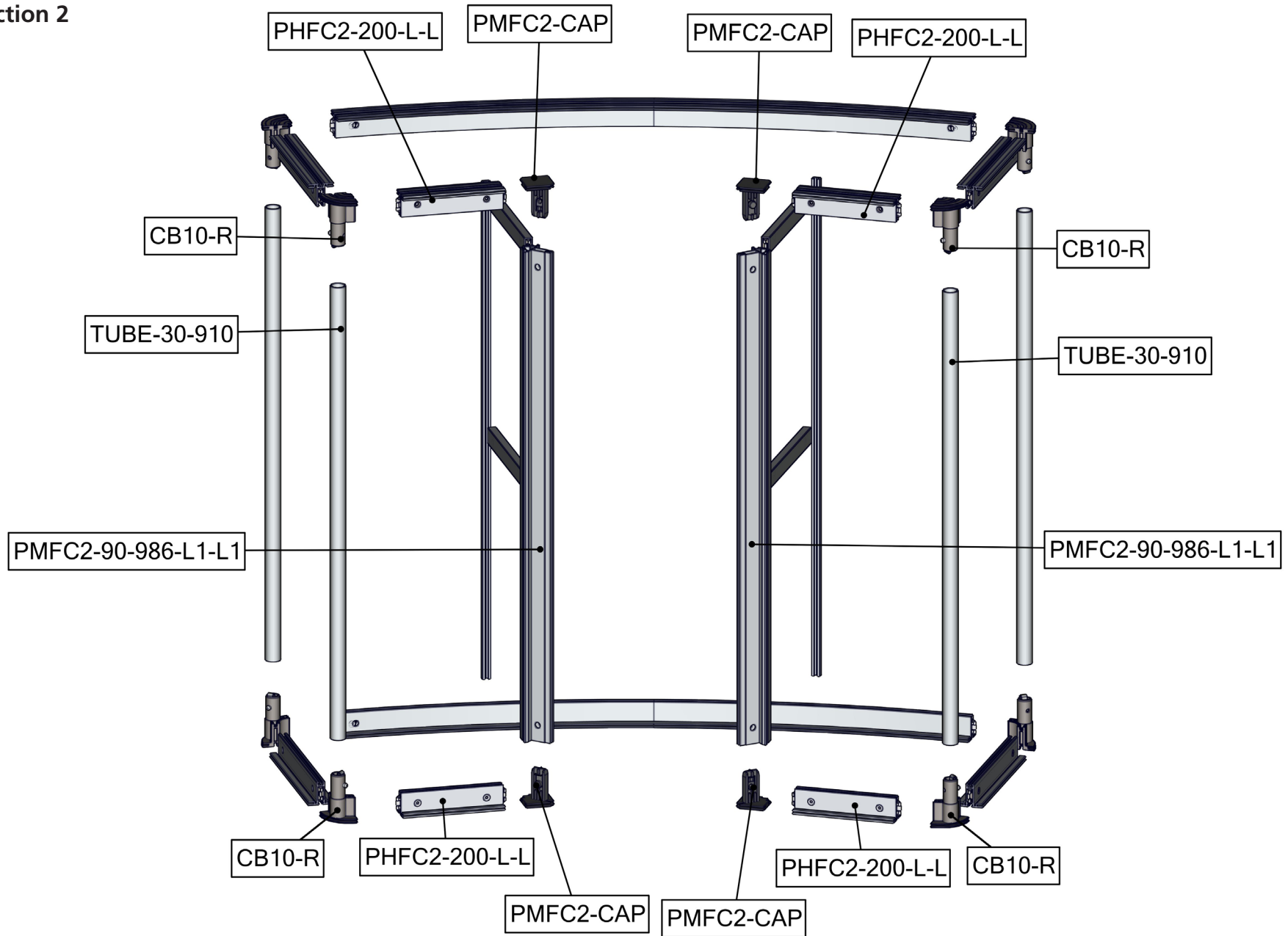

# Exploded View

VFC-02  
Section 3

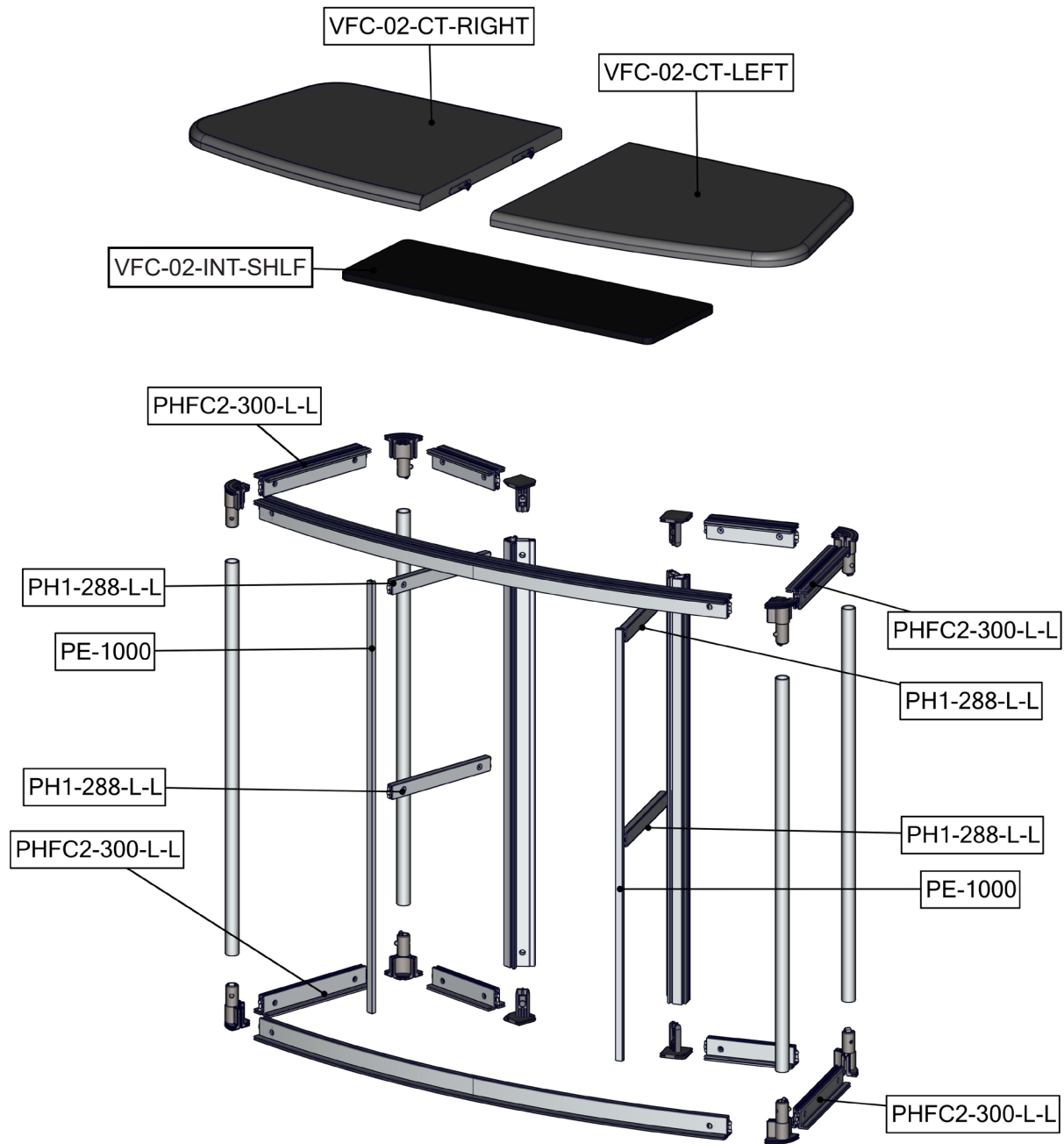

# Kit Assembly

## Step by Step

### Step 1.

Gather the components to build the counter frame sections 1 and 2. Use the Exploded View section 1 and 2 for part labels.

Reference Connection Method(s) 1, 2 and 3 for more details.

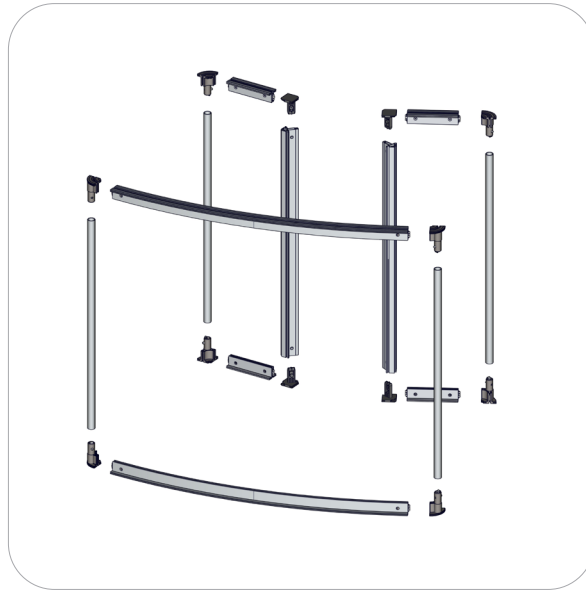

### Step 2.

Gather the components to build the counter frame section 3. Use the Exploded View section 3 for part labels. Use section 3 to merge sections 1 and 2.

Reference Connection Method(s) 2, 3 and 4 for more details.

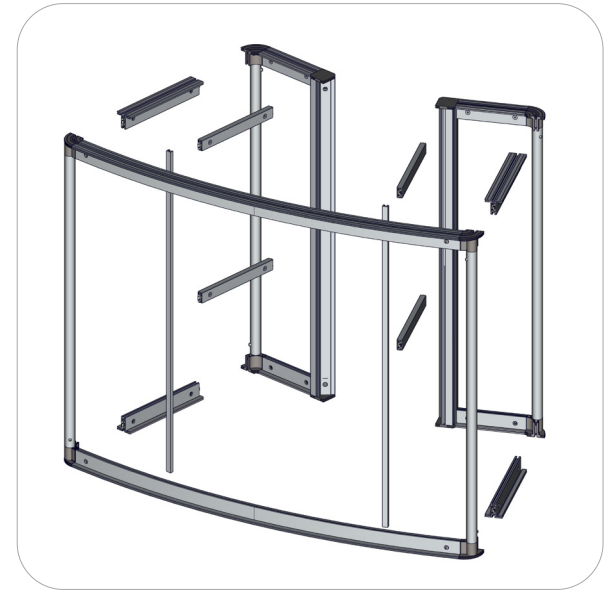
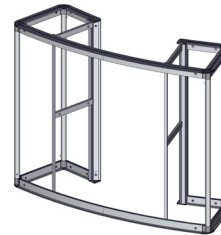

### Step 3.

Apply the counter fabric graphics by pressing the edges of the graphic into the extrusion fabric channel.

Reference Connection Method(s) 5 for more details.

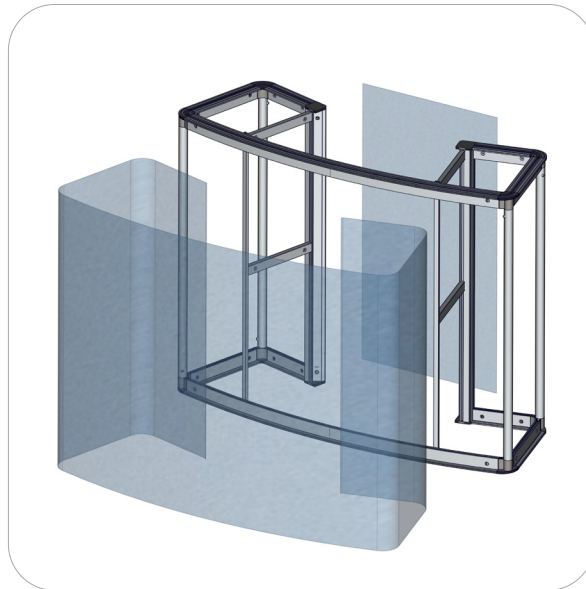
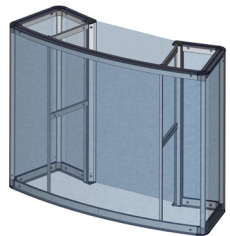

### Step 4.

Gather the components to build the counter top and shelf. Use the Exploded View section 3 for part labels.

Reference Connection Method(s) 6 for more details.

Setup is complete.

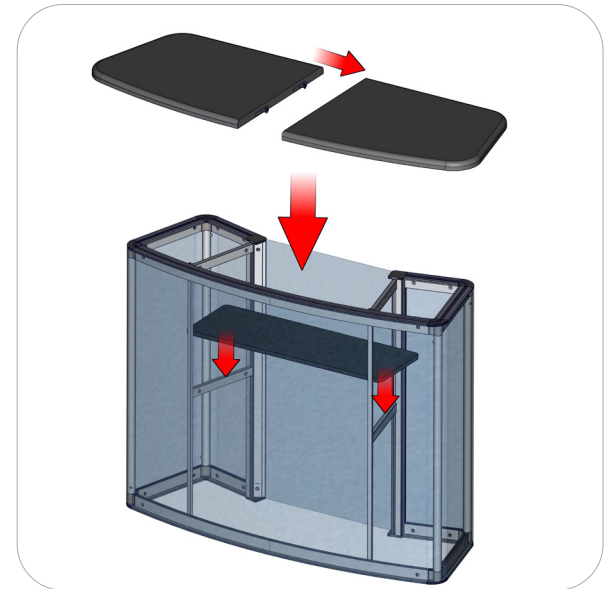
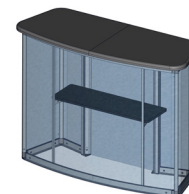



# Connection Methods

## Connection Method 1: PMFC2-90-CAP



First, press button to insert the cap into the extrusion. The button will snap in place.

## Connection Method 2: PMFC2 / PHFC2



First, with the cam lock disengaged, place the cam lock teeth into the extrusion channel. Second, use the allen key tool to lock it in place. Make half turns clock-wise to engage the cam lock. Do not over tighten the lock buttons.

## Connection Method 3: CB10-R / PHFC2

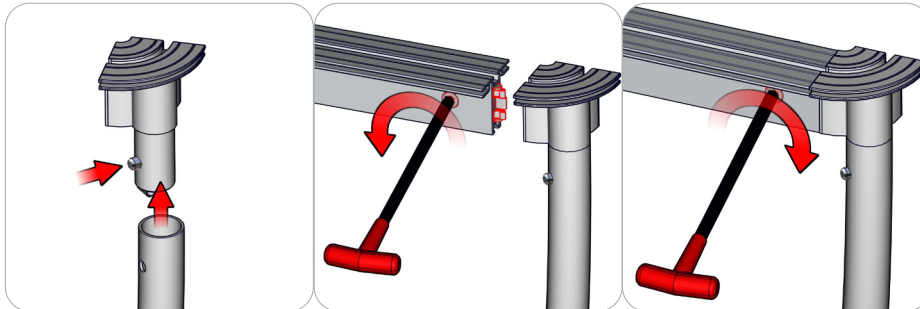

First, press and hold the snap button while you slide it into the tube. The snap button connection is secure when it protrudes through the tube hole. Second, using the allen key tool, disengage the cam lock in the extrusion end and place its teeth into the CB10-R channel. Third, with the cam lock teeth in the channel, use the allen key tool to engage the cam lock. Make a half turn to lock, do not over tighten. Repeat for opposite end.

## Connection Method 4: CAM LOCK / PE

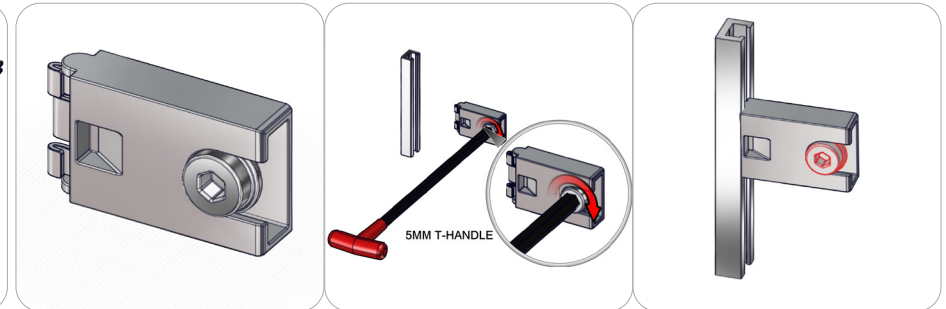

First, with the cam lock disengaged, place the cam lock teeth into the extrusion channel. Second, use the allen key tool to lock it in place. Make half turns clock-wise to engage the cam lock. Do not over tighten the lock buttons.

# Connection Methods

## Connection Method 5: Silicon Edge Graphic (SEG)

VFC-02-A-G VFC-02-B-G

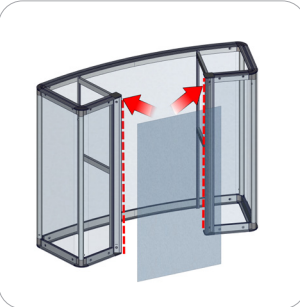
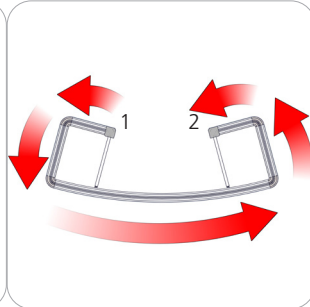
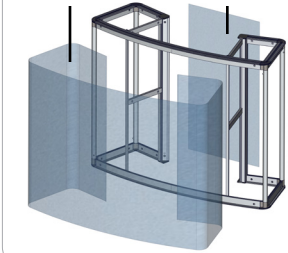

First, at point 1, start pressing VFC-02-A-G fabric SEG from top to bottom of the counter fabric channels. Second, work the SEG across the rest of the top and bottom counter fabric channels to point 2. At point 2, start pressing the fabric SEG from top to bottom of the counter fabric channel. Third, apply VFC-02-B-G fabric SEG from top to bottom of the counter fabric channels.

## Connection Method 6: ROTO LOCKS

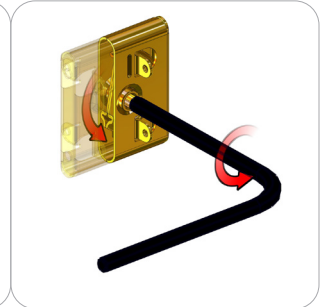
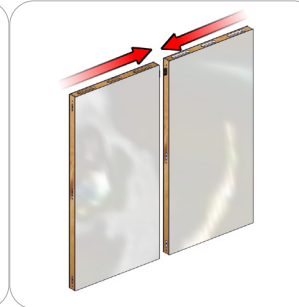
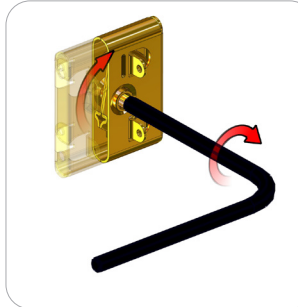

First, with the provided hand tool, disengage the male ROTO LOCK by turning counter clock-wise. Second, use the doll rods to help align the wood panels in place. Third, with the provided hand tool, engage the male ROTO LOCK into the female receptor with a snug 3/4 turn.